

An ultrasonic motion tracker for VR usage

Ján Cíger
Jan.Ciger@st.fmph.uniba.sk

Faculty of Mathematics and Physics
Comenius University
Bratislava / Slovakia

Abstract

The interaction in 3D space is gaining on importance. The classical means of interaction with mouse and keyboard are often unsatisfactory for spatial applications, virtual reality is used more often than ever and so there is an increasing need for a cheap and accurate 3D positioning device.

Such 3D locator was designed and constructed — it is a data acquiring device for tracking movement of the operator's hand. Alternative usage is as "3D mouse", which could be utilized in graphics systems as a replacement of a traditional "2D" mouse. The aim of this design is to gain a new faster way of entering points, curves and animations.

KEYWORDS: Virtual reality, motion capture, 3D mouse

1 Introduction

Contemporary methods of interaction in 3D space have some significant drawbacks :

1. **Scene visualisation is mostly 2D (on the monitor), but displayed objects are three-dimensional.** Usage of projection helmets and glasses is not common practice because of low resolution and high price. Usage of lasers or volumetric displays for displaying 3D images is in development and is not suitable for general usage yet.
2. **Input devices are mostly constructed for using in plane only.** Mouse and tablet can be used for interaction in 3D space, but there is a need for some additional support from software and abstraction of the user. Typical is employment of three views to the scene — one top-view, one front-view and one from the side (3D Studio from Autodesk). Another approach is one perspective view combined with one additional view defined by the user (TrueSpace from Caligari). Both this systems employ various constraints to cursor movement, such as snap-modes or movement in one or two axes only.

These are needed to simplify the interaction with objects in the scene for the user.

Some of the possible enhancements of the interaction methods :

- **Enhancing existing input devices.** For example “SpaceBall”, joysticks with spinning handles, force–feedback devices etc.
- **Using devices, which were constructed for 3D interaction from start.** Examples are data–gloves and 3D mice.
- **Motion–capture systems.** These are used mostly for animations and are too expensive for the common use.

1.1 Types of 3D locators

1. **Optical and opto–mechanical systems.** Optical systems use markers, which are placed on the moving object and tracked with cameras. They are used mostly in motion–capture systems. Opto–mechanical systems employ glass or plastic fibers, acting as waveguides. When the fiber is deformed, light evades from it and this can be detected as change in the intensity of the light on fibre’s end. Typical usage is in data–gloves and data–suits.
2. **Mechanical systems.** These use complicated system of arms and ankles with several degrees of freedom. Each ankle has sensor for detecting angular movement, some systems are equipped with force–feedback. They are accurate and relatively cheap, but rather unwieldy. They are used mostly in robotics and simulators.
3. **Locators employing acoustic waves.** Usually work with ultrasonic signal, idea is very simple — they measure **Time Of Flight** (TOF) of the emitted signal from transmitter to several receivers. Using at least three non–collinear receivers enables calculation of the position in the working volume. This principle was used in the design of the 3D mouse.
4. **Magnetic trackers.** Magnetic sensors are widely used because they are cheap, but they have several disadvantages — low accuracy, sensitivity to interference caused by large metallic objects and small range.
5. **GPS based systems.** These are used mostly in robotics and navigation, have only limited usage in VR, because they don’t work inside of buildings, have low resolution (several meters) and are very expensive.

2 How does it work

In articles [3], [4] was published a simple method for position determination in 3D space with possible robotic application. These works gave an inspiration and basic knowledge about using ultrasonic waves for position sensing.

The idea of the 3D mouse is actually very simple. The basic elements of the 3D mouse are at least three ultrasonic receivers (non-collinear) and one transmitter as shown at fig. 1.

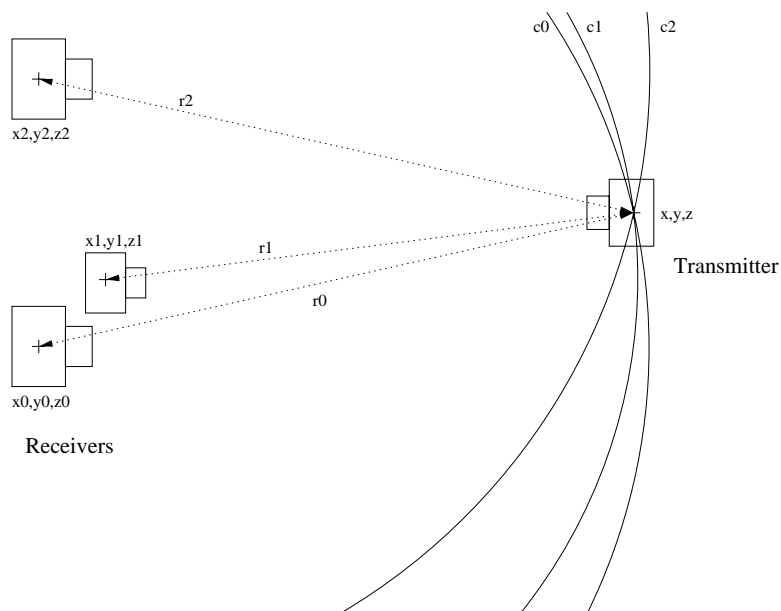

Figure 1: Working arrangement

The position in 3D space is calculated as follows :

1. Burst of the ultrasonic signal is emitted from the transmitter and “stop-watch” is started.
2. After arrival of the ultrasonic wave to the receiver, “stop-watch” is stopped and calculations start.
3. From the measured time and known velocity of the sound in the air (cca $340 \text{ m}\cdot\text{s}^{-1}$), distance to the each receiver is calculated. We use a simple formula (1).

$$r_i = t_i \cdot v \quad (1)$$

r_i is the calculated distance to the i -th receiver, t_i is the measured time (TOF) and v is the velocity of the sound in the air.

4. Position in space is calculated from already known distances by solving equation system (2).

$$\begin{aligned}
(x - x_0)^2 + (y - y_0)^2 + (z - z_0)^2 &= r_0^2 \\
(x - x_1)^2 + (y - y_1)^2 + (z - z_1)^2 &= r_1^2 \\
(x - x_2)^2 + (y - y_2)^2 + (z - z_2)^2 &= r_2^2
\end{aligned} \tag{2}$$

x_i, y_i, z_i are known coordinates of receivers, r_i is the calculated distance from transmitter to the corresponding receiver and finally x, y, z are coordinates determining position of the transmitter in 3D space. System (2) can actually have two solutions, but one of them can be safely ignored, because it describes a point behind the receivers plane.

3 Construction

The 3D locator consists from these parts :

- Moving handle with ultrasonic transmitter
- Plane with four receivers (three of them are sufficient, the fourth is for maintaining some redundancy and improving accuracy).
- Interface to the computer (PC)

All these parts are shown on the fig. 2.

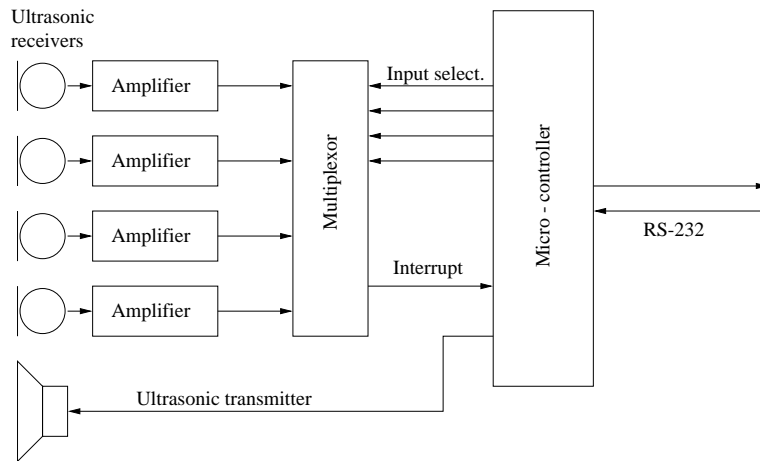

Figure 2: Schematic diagram

As ultrasonic receivers and transmitter are used crystal units with resonance frequency at cca 40 kHz. Each receiver has its own amplifier with amplification ratio 900 : 1. These receivers are multiplexed into one signal, which drives interrupt line of the micro-controller. Not shown, but important parts are driver and receiver of RS-232 line and power supply.

Micro-controller used is an 8-bit type AT89C2051 from Atmel. It contains 128B RAM, 2kB Flash EPROM, 2 counters/timers, serial interface and analog comparator. Usage of this progressive part simplified construction a lot, because all the hard work is done inside the micro-controller. It has these main tasks :

- Generates 40 *kHz* signal for the transmitter
- One of the timers acts as an accurate “stop-watch”
- Does first pre-filtering of measured data
- Communicates with controlling PC via RS-232 interface (serial line)

Construction was inspired by article [7], where is described an ultrasonic motion detector for security applications. The digital part of the construction is an original work.

The simplified algorithm of the micro-controller can be described as follows :

1. After power-up or reset, micro-controller is awaiting configuration data and the starting command.
2. When starting command arrives, endless loop of measuring and sending data begins.
3. TOF is measured for all four receivers.
4. Status of the two buttons on the handle is detected and saved.
5. Test is performed, if there was some movement compared to previous measurement. If no, data are discarded.
6. Data are pre-filtered, most of largest errors are filtered out.
7. Pre-processed data are sent to the host-computer via serial line.
8. Process repeats from point 3.

Achieved parameters can be summarized in the following table :

Parameter	Value	Remark
Degrees of freedom	3	mouse cannot determine pitch and roll
Resolution	cca 0.5 <i>cm</i>	theoretically should be possible to achieve even 1 <i>mm</i>
Working volume	cca 40 × 40 × 40 <i>cm</i>	typical (desktop) installation
Max. working distance	cca 3 <i>m</i>	in <i>z</i> axis, distance of the transmitter from receivers plane
Max. angular error	cca 15°	angle, by which it is possible to receive signal from the transmitter
Sampling frequency	cca 20 <i>Hz</i>	depends on distance of the transmitter to receivers
Costs	cca 6000 <i>Sk</i>	Cost of the material and salary of the one skilled person to build it

4 Software

3D mouse without good software would be only a dead piece of plastic, so several programs were developed. All software was written for free Unix clone — Linux and graphics was done with help of the Mesa library (free OpenGL clone). Software consists of these programs :

- Mouse “driver” — it’s main task is communication with hardware. The term driver is little inappropriate, because it is a user-space task, actually a separate thread of execution. Besides communication, it provides the application with calculated and filtered coordinates of the moving transmitter.
- Calibrator — it serves as a mean to standardize each installation of the 3D locator. It calculates normalization matrix, which is used to convert calculated coordinates of the 3D mouse (transmitter) to the unified cube.
- Simple metaballs modeller — this is a demonstration application, which shows some capabilities of the 3D mouse. The modeller is actually very simple, allows limited count of spherical primitives only. Displaying of metaballs is done by the “Marching Cubes” algorithm, which was adopted from [5] and calculations needed were taken from [2] and [1]. User interface of the modeller was influenced mostly by [6], [8]. It is actually very simple and was not designed with serious work in mind. It cannot even save the modelled object into the file ... Figures 3 and 4 show the modeller “in action”.

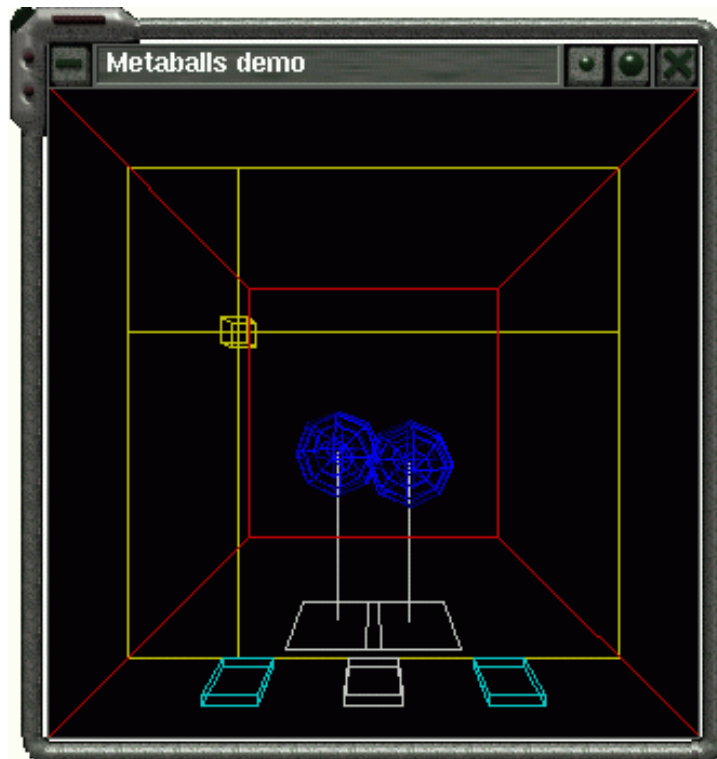

Figure 3: Skeleton of metaball

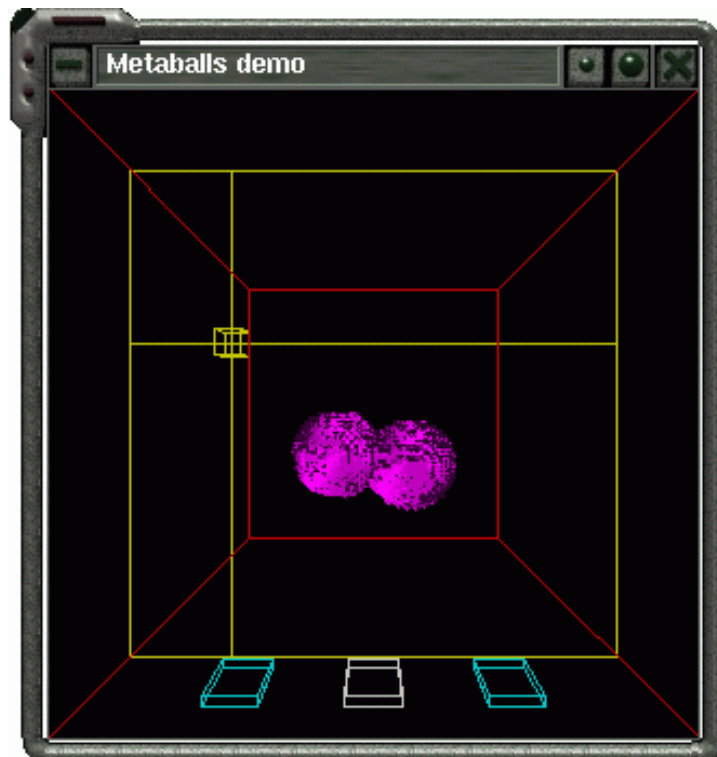

Figure 4: Corresponding metaball

5 Conclusions

The choosed design was rather successful and surprisingly simple to build. But there remain some problems to solve. The most important and most annoying are

ultrasonic echoes from near objects. They interfere with measuring of distance and add noise to the measured data. Thus filtering has to be done, but this slows things down a lot. There is an idea to move the filtering algorithm to micro-controller and do it in hardware in some future version of the firmware, but this will need more computational power than used type of micro-controller can provide. Another idea is to add remaining three degrees of freedom (rotations), but this will require major changes in construction.

Software part of the project needs some more work too. One of the most challenging ideas is integration with some well known modeller such as Caligari's TrueSpace or Autodesk's 3D Studio. Some work on TrueSpace is already done, but due to lack of time, progress is very slow.

This project can be an example, how can be VR technology used even with a tight budget and simple equipment.

References

- [1] B. Beneš, P. Felkel, and J. Žára. *Moderní počítačová grafika*. Computer Press, 1998.
- [2] P. Bourke. <http://www.mhri.edu.au/~pdb/modelling/implicitsurf/>. Introduction to metaballs.
- [3] F. Figueroa and A. Mahajan. A robust method to determine the coordinates of a wave source for 3d position sensing. *ASME Journal of Dynamic Systems, Measurements and Control, Vol 116, pp. 505 511*, 1994.
- [4] F. Figueroa and A. Mahajan. An automatic self installation and calibration method for a 3d position sensing system using ultrasonics. *ASME Journal of Dynamic Systems, Measurements and Control*, 1996.
- [5] P. Heckbert. *Graphics Gems IV*. Academic Press, 1994.
- [6] R. Herr and P. Slavík. Interaction in 3d space and 3d window manager. In *Selected Readings 1995 of the Computer Graphics Group, part II*. Dept. of Computer Science and Engineering, Czech Technical University Prague, 1995.
- [7] P. Strážnický. Ultrazvukový detektor pohybu. *Praktická Elektronika A Radio*, 4:14,15, 1996.
- [8] H. Wurnig. Design of a collaborative multi user desktop system for augmented reality. In *Proceedings of the CESC G '98*, 1998.